

*The miracles of science™*

# **PROPER USE OF LOCAL EXHAUST VENTILATION DURING PROCESSING OF PLASTICS**



Responsible Care®  
A Public Commitment

# PROPER USE OF LOCAL EXHAUST VENTILATION DURING PROCESSING OF PLASTICS

## INTRODUCTION

Melt processing of plastic resins (e.g. extrusion, blow moulding, injection moulding and wire and cable coating), related activities like equipment cleanout and purging, and cleaning of metal parts by burning off plastic material, will release gases, vapours or fumes that may be harmful to your health or create undesirable odours.

Other operations, such as regrinding, handling of resin and additives, drying certain resin types, opening rotomoulded parts and grinding or buffing to remove trim or surface defects on parts can also release contaminants that may be harmful or cause nuisance dusts.

The most effective way to control these emissions is to “capture” them at the point of release and remove them by exhaust ventilation before they are dispersed into the air you may breathe. This “capture” technique is called local exhaust ventilation (LEV).

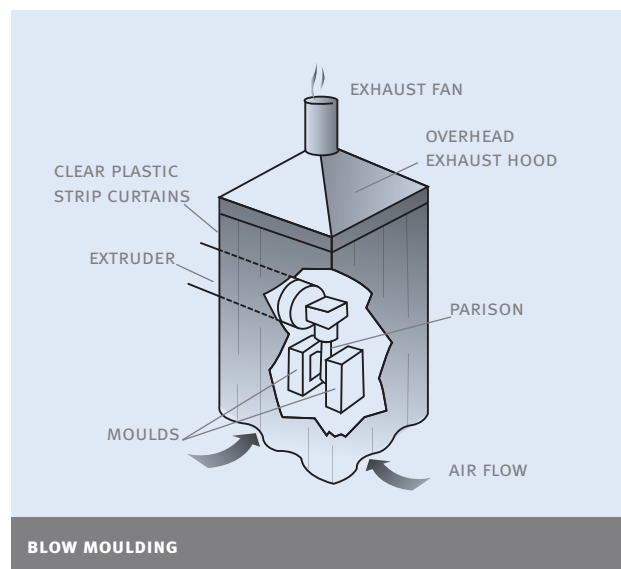
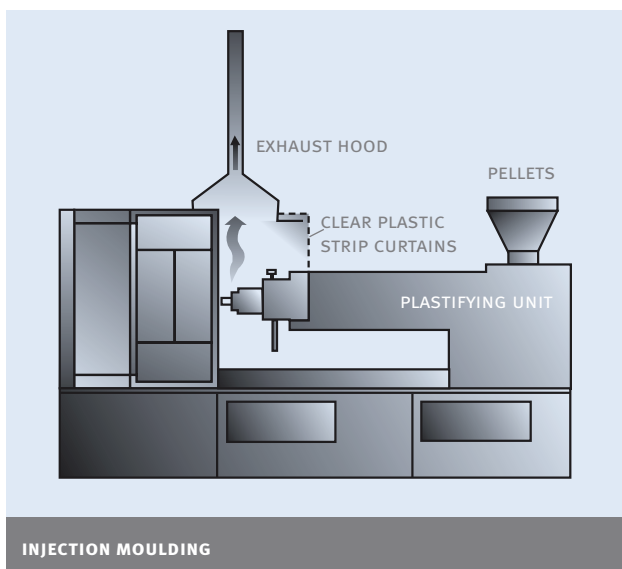
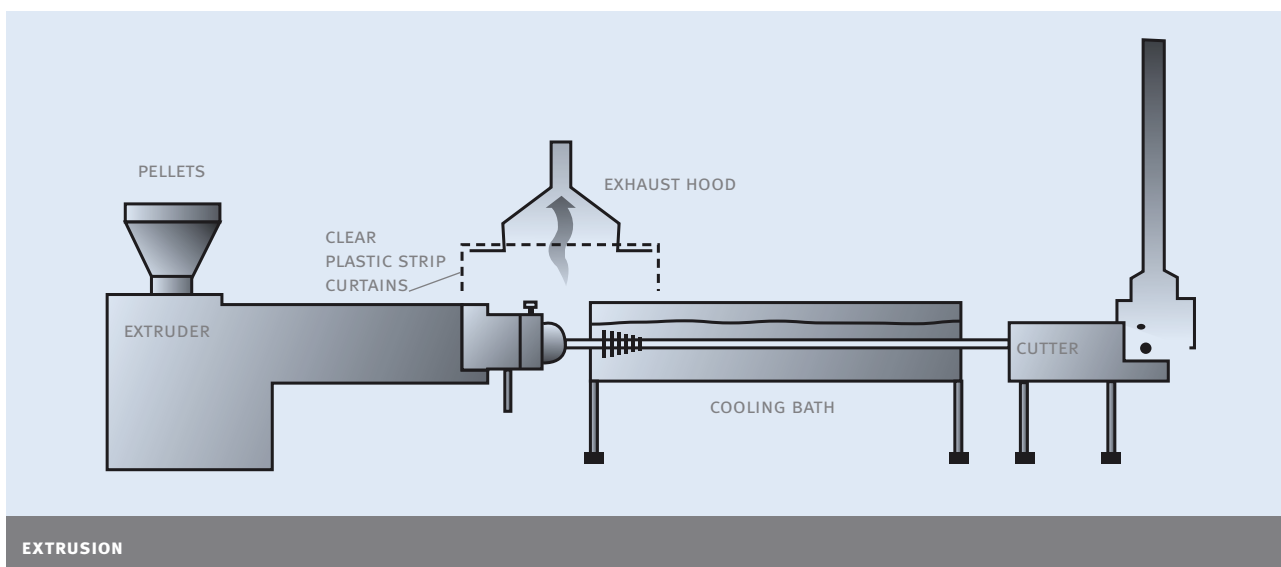

## THE REASONS LEV IS SO EFFECTIVE

- Only a relatively small volume of air is required to capture and remove airborne contaminations released at a point source compared to the very large volumes required to try to change the air in an entire area of a building.
- Capture of contaminants at the source can virtually eliminate any exposure of workers to the contaminants.

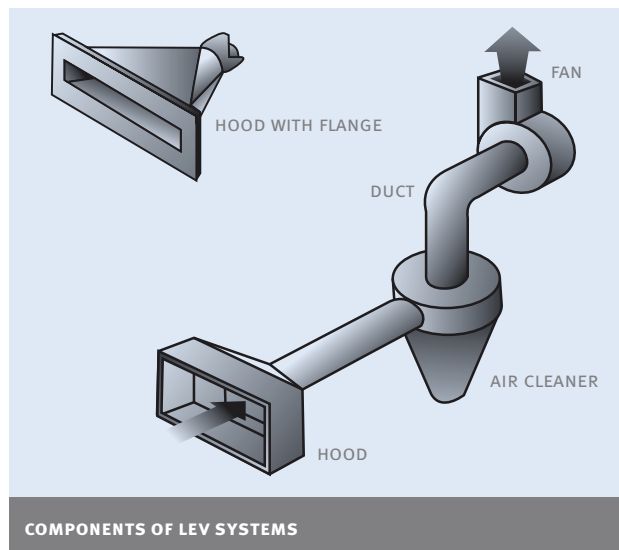

## SOME PRINCIPLES TO FOLLOW IN USING LEV

1. The LEV system is made up of an exhaust fan, which pulls air and contaminants into the exhaust hood and through the ducting and an air cleaner to remove contaminants (where appropriate), before exhausting air outdoors.
2. The hood should be shaped to enclose the source as far as is practical yet still allow access to the equipment for normal operation. The hood should be removable or connected to an adjustable duct that can be moved aside from extrusion or moulding equipment for maintenance or troubleshooting. Adjustable ducting of this type is commercially available. Care should be taken to avoid kinking or excessive lengths of flexible tubing.

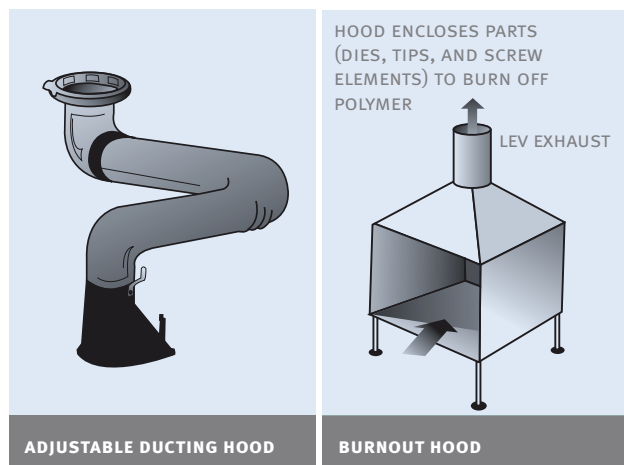

- When exhaust air enters the hood, it will carry contaminants with it and convey them through the ducting and air cleaner to the fan and the exhaust point. The air velocity (speed) at the point where contaminants are released should usually be at least 0.5 meters per second. This is termed the “capture velocity”, that is the air velocity that will capture contaminants at the source and pull them into the hood. This capture velocity can be measured with a special flow meter as shown below.

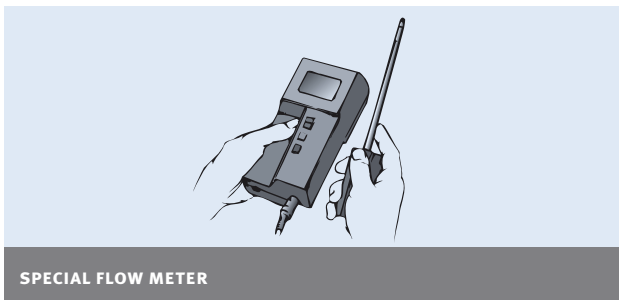

SPECIAL FLOW METER

- The hood is the most critical part of the LEV system and a simple check of its effectiveness can be made by using a ventilation “smoke tube” to produce a stream of dense white chemical “smoke” at the location where contaminants are released. The smoke will follow the air flow and should be rapidly captured (within 1-2 seconds) by the exhaust air and swept into the hood (see illustration: Ventilation “Smoke Tube”).

If smoke escapes the hood and moves into the surrounding air, then some adjustment of hood location and/or air velocity will be needed. Additional enclosure around the hood may also be considered, for example, by adding heavy plastic strip curtains (see illustration: Hood for Injection Moulding or Extrusion Die).

Note: Keep plastic curtains away from hot surfaces. High temperatures cause the plastic to become brittle and discoloured.

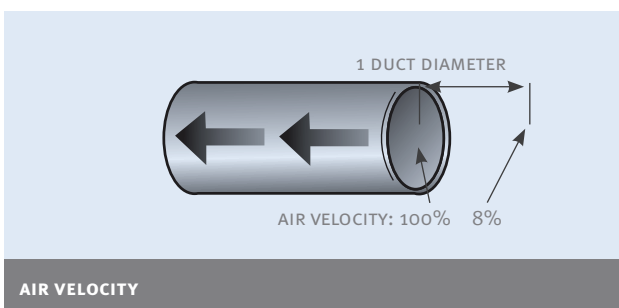

AIR VELOCITY

**Remember:** The hood should be as close to the source as is practical. Tests have shown that the air velocity diminishes rapidly as the distance from the hood opening is increased (see sketch before).

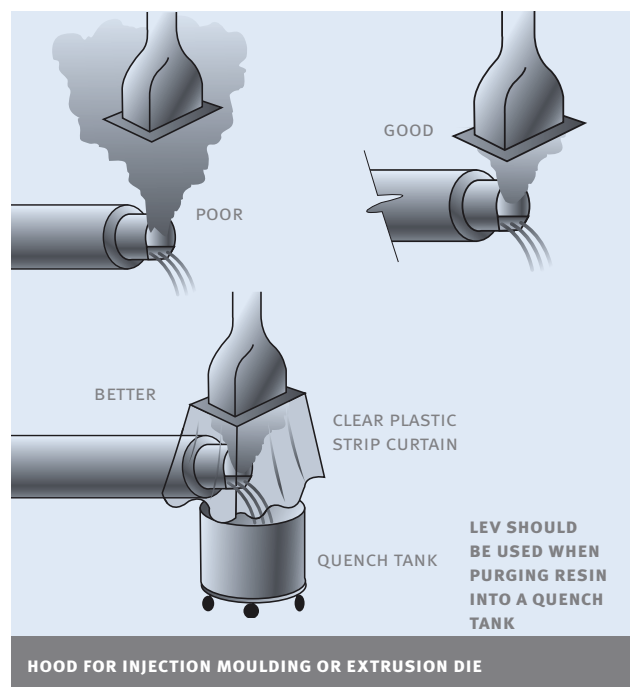
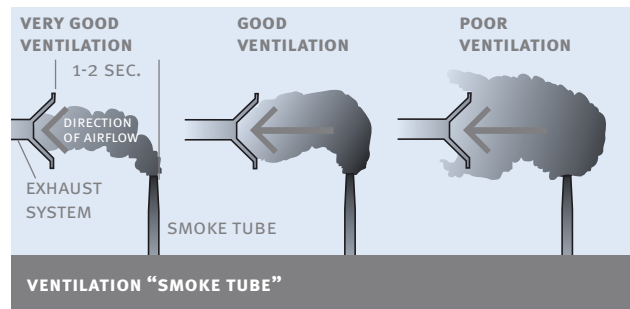

- The capture effectiveness of a hood can be improved by using flanges (see illustration: Components of LEV Systems sketch). The flanges restrict airflow from behind and from the sides of the hood and maximise airflow from the front. Volatiles emitted by materials released from extruder barrels (incl. plops) and extruder barrel vents should be captured by LEV. In any case, emissions to workplace air should be minimised by immediate discharge of molten material (e.g. plops) into a metal container with water and / or with a lid, as appropriate for conditions.

**6.** Air cross-currents around the area where contaminants are generated can disperse the contaminants into the surrounding air before they are captured by the hood. Portable fans, open windows or air from ceiling diffusers can cause cross-drafts which interfere with the LEV system.

You can improve this situation by shielding the operation from cross-drafts, for example by using a partial enclosure with plastic strip curtains. Never locate portable fans so that air flows over hot polymer towards workers. Air should always carry contaminants away from workers.

**7.** If the contaminants contain dusts, mists or fumes, the air velocity in the ducting must be high enough to prevent these materials from settling out in the ducting – typically in the range 12.5 – 25 m/s. The product Material Safety Data Sheet will provide information on the contaminants expected to be produced during processing or thermal decomposition.

**8.** Airflow in LEV ducting can vary, for example, with changes in fan operation, plugging of filters in air cleaners, build-up of deposits in the ducting, addition of extra branches and hoods to the LEV system and positioning of portable or adjustable LEV systems, etc.

A simple way to monitor the system performance, once it is working properly, is to install a gauge to measure the static pressure in the exhaust duct. Workers can check the gauge for changes in static pressure – in either direction – which mean that the airflow has changed and, therefore, a maintenance check of the fan, duct or air cleaner is needed, using appropriate Personal Protection Equipment (PPE).

Periodic checks with a smoke tube near the hood inlet will also indicate significant airflow changes.

**9.** Air discharged outdoors must comply with any applicable regulations or permits for acceptable concentrations of chemical contaminants. As a responsible practice, it is recommended that exhaust air be treated by an air-cleaning device to remove all or most of the contaminant gases, vapours, dusts, mists or fumes present in the air, before discharge. Locate exhaust stacks as far away from air intakes as possible to prevent entrainment of emissions back into the workspace. A distance of 15 meters is usually considered to be adequate.

**10.** An LEV system will only work effectively when sufficient “make-up” or supply air is brought into the building to replace that exhausted outdoors. This is a particular concern when LEV systems are retrofitted in cold climates requiring indoor heating.

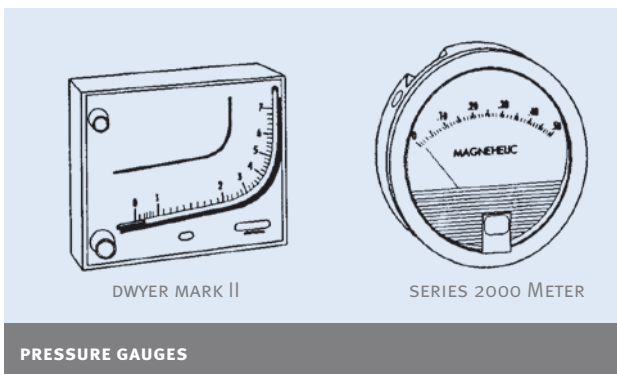

## USE OF PORTABLE EQUIPMENT

For such applications as small-scale grinding or trim removal on plastics parts, a commercially available, portable LEV unit may be satisfactory. These units are available in various sizes and incorporate a fan, air cleaner, ducting and an exhaust hood to capture contaminants and remove them before exhausting the cleaned air back into the workplace. Such units can be recommended for capture and removal of low-toxicity dusts from plastic parts. In cases where toxic or irritating gases or vapours are released, it is important to ensure that the air cleaning device is the correct type to remove the contaminants, so that the exhaust air can be safely returned to the operating area (see illustration alongside). If there is uncertainty about air cleaning effectiveness, the exhaust air should be vented outside.



PORTABLE LEV UNIT

## DESIGN OF LEV SYSTEMS

This brochure is intended to assist you in understanding how LEV can improve your operation. However, it is important to obtain professional assistance in designing a LEV system to ensure that it will meet your expectations for performance, cost, maintenance, noise level and compliance with local workplace and environmental regulations or permits. For example, worker exposure to airborne contaminants should always be maintained below regulated or recommended exposure limits. It is usually more economical to install a single fan, blower and ducting to service a number of similar operations (e.g. several extruders or moulding machines) than to install a separate system for each operation.

The principles of design are described in standard texts and handbooks – see following listings.

## REFERENCES AND SOURCES FOR FURTHER INFORMATION

The list below provides references to some standard texts and publications as well as commercial sources of equipment and test devices. These are a few examples of available sources and DuPont does not specifically endorse them. Other sources not mentioned here are also available.

### PUBLICATIONS

**1.** “Industrial Ventilation: A Manual of Recommended Practice”. Published by American Conference of Governmental Industrial Hygienists (ACGIH). This manual, which is updated regularly, contains detailed information on all aspects of industrial ventilation and provides many hood designs for specific operations, together with guidance on air-cleaning methods (in English).

<http://www.acgih.org/store/ProductDetail.cfm?id=1668>

**2.** “Industrial Ventilation Workbook”. Author: D. Jeff Burton. Published by American Conference of Governmental Industrial Hygienists (ACGIH). This practically oriented text has minimal theory and many examples and is appropriate for those with little background knowledge in ventilation (in English).

<http://www.acgih.org/store/ProductDetail.cfm?id=7>

**3.** “Controlling airborne contaminants at work: A guide to local exhaust ventilation (LEV)”. Health and Safety Guidance (HSG) issued by the Health and Safety Executive (HSE), UK (in English).

<http://www.hse.gov.uk/pubns/books/hsg258.htm>

**4.** “Taschenbuch für Heizung + Klimatechnik 11/12”. Author: Hermann Recknagel, Eberhard Sprenger, Ernst-Rudolf Schramek. Publisher: Oldenbourg Industrieverlag München (in German).

<http://www.oldenbourg-industrieverlag.de/produkt.php?index=books&gruppe=B&nummer=66019402>

### TRADE ASSOCIATIONS FOR CONTRACTORS WHO FABRICATE AND SUPPLY VENTILATION SYSTEMS AND SERVICES

**1.** Mechanical Contractors’ Association of America (MCAA). USA tel: +1 301 869-5800.

<http://www.mcaa.org/>

**2.** Sheet Metal and Air Conditioning Contractors’ National Association (SMACNA). USA tel: +1 703 803-2980.

<http://www.smacna.org/>

**3.** National Environmental Balancing Bureau (a joint program of MCAA & SMACNA). Has a free listing of certified contractors who provide ventilation system testing and balancing services. USA tel: +1 301 977-3698.

<http://www.nebb.org/>

**4.** Heating and Ventilation Contractors’ Association (HVCA). UK tel: +44 20 7313 4900.

<http://www.hvca.org.uk/>

**5.** REHVA - Federation of European Heating and Air-Conditioning Associations. Belgium tel: +32 2 5141171.

<http://www.rehva.eu/>

### EQUIPMENT AND DEVICES

**1.** Ventilation Smoke Tubes to visually check air currents around an exhaust hood. Check Internet under ‘Ventilation Smoke Tubes’. Available from: M.S.A., Dräger.

**2.** Air Velocity Meters (Anemometers) to measure air-flow velocity. Check Internet under ‘Anemometers’. Available from: In North America – Alnor Instruments, Sierra Instruments, T.S.I. In Europe – Testoterm, Wilhelm Lambrecht.

**3.** Static Pressure Gauges to monitor airflow in ducts. Check Internet under ‘Static Pressure Gauges’. Available from: Alnor Instruments, Dwyer Instruments.

**4.** Portable LEV Units: Check Internet under ‘Air Extraction Systems’. Available from: In North America – Nederman, PlymoVent, Roberts-Gordon Canada. In Europe – Kiekens Products.

**5.** Adjustable Ducting Systems. Check Internet under ‘Air Extraction Systems’. Available from: In North America – Nederman. In Europe – Norfi.

### For additional information we suggest contacting your local Occupational Health and Environmental Safety Supplier.

This brochure is intended to assist you in your general understanding of how LEV can improve your operation. It is not intended as an endorsement of any particular LEV system. It is important to obtain professional assistance in designing a LEV system to ensure that it will meet your expectations for performance, maintenance, costs and compliance with local workplace and environmental regulations and permits.

